



DAVIE

The Davie Strategic Journey: Generation 2040



The Davie Strategic Journey: Generation 2040

In our 200-year history, there has never been a more compelling time for Davie. Acquired by the Inoceca Group in 2012, Davie has regained its position as the premier builder of cutting-edge ships for the Government of Canada and the private sector.

Since 2012, we have delivered many industry firsts. This includes some of the world's most complex and pioneering vessels: dynamically positioned subsea construction vessels, dual-fuel ferries and a combat support ship, which was the largest and greenest naval vessel ever delivered by a Canadian facility.

Davie to deliver for decades under National Shipbuilding Strategy

The ultimate recognition of our skills, infrastructure and capabilities was Canada's confirmation of Davie as a pre-qualified partner in the National Shipbuilding Strategy (NSS).

NSS inclusion means a guaranteed orderbook of high-value contracts extending into the 2040s. This puts Davie in a position of unprecedented strength. Cyclical downturns are effectively eliminated providing stability and highly favourable conditions for us to invest, grow and generate value. Our already multi-billion-dollar economic impact on Canada will increase exponentially, while we support thousands of people employed directly by Davie, and throughout our supply chain.

Davie will maximise the opportunities presented by our multi-generational NSS contracts by investing significantly in our unique facility – already by far Canada's largest and highest capacity. Ensuring the development and sustainability of a vital national and economic security capability is a win-win for Canada and, increasingly, the private sector.

Unique experience, skills and people with a winning mentality

Our renowned workforce is known throughout North America for their exceptional capabilities, which have regularly extended beyond ships to heavy industrial machinery.

This includes making sonar domes and aircraft elevators for the US Navy to air-tight doors for Canada's nuclear reactors. In fact, whenever a task is too complex, absolutely mission critical and with the tightest of deadlines, Davie has been the first port of call.

We have honed these skills and bring our experiences and collective can-do attitude to the shipbuilding value chain that defines us today. Guided by our unique Davie Spirit, no-one designs, builds and sustains complex, ultra-modern, super reliable ships like Davie does.

World-Class International Maritime Centre of Excellence

In this new era as Canada's national shipbuilder, Davie is also rapidly emerging as a world-class, international maritime centre of excellence. Our success is stimulating pride in our Québec home and across Canada, inspiring the next generation of entrepreneurs, industrialists and shipbuilders.

The National Icebreaker Centre will lead the renewal of Canada's entire icebreaking fleet. It will also create international exports in a market defined by an aged global fleet and increasing traffic in polar and ice-covered waters.

In addition to renewing its icebreaker fleet, Canada has selected Davie as a long-term, through-life support centre for the Royal Canadian Navy (RCN). Our Naval Maintenance Centre of Excellence will sustain the RCN's surface combatant fleet into the far future.

Davie has also been selected to lead the rejuvenation of Canada's much-needed federal ferries.

We won't stop there. Our vision and ambition to shape and lead our sector will see us pursue a multitude of opportunities where we can deliver tangible, long-term value to our clients and our stakeholders.

Our future has never been so bright.



Our vision and ambition will see us pursue a multitude of opportunities where we can deliver tangible, long-term value to our clients and our stakeholders

James Davies,
President & CEO



Partnering with Canada under the National Shipbuilding Strategy has created a stable, multi-generational opportunity that will generate value for decades to come.

Alex Vicefield, Founder & CEO Inoceca Group

4

Founders' Message

Creating a stable, sustainable, future focused business

6

Who We Are and What We Do

Vision Mission, Values, Strategy and Operating Model

8

Davie by Numbers

Everything you need to know about Davie and the value it creates

22

Innovation Incubator

Identifying, meeting and exceeding customers' future needs

10

Davie Timeline

Key historic and future milestones and key ships through the ages



26

National Icebreaker Centre

Canada's Icebreaker Centre of Excellence



16

National Shipbuilding Strategy

Davie becomes a generational government partner

28

Through Life Partner

Canada's only full-service provider of Through Life Solutions

32

Davie Spirit for a New Generation

A destination for the brightest and best talent



18

Pride of Québec

Davie is proud to partner and share success with our home province



20

Asterix: Force Multiplier

Personifies Davie's rejuvenation as a shipbuilding force



24

Next Generation Shipbuilding Facility

Canada's only mega yard explained

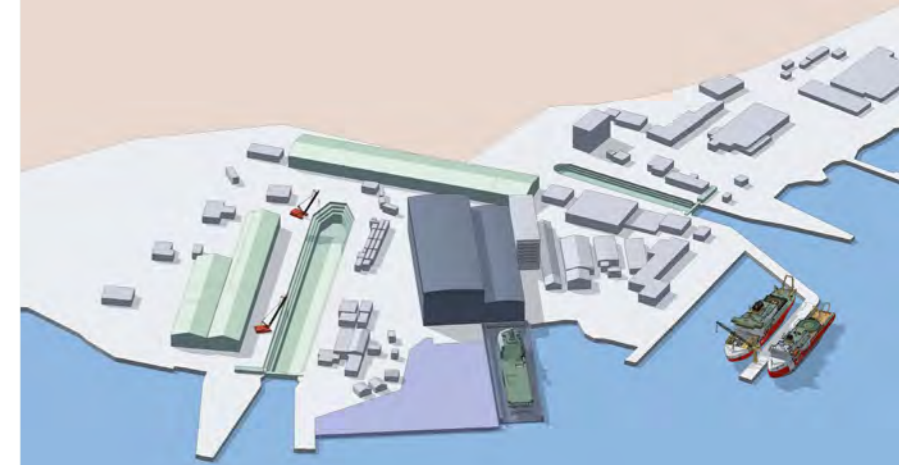

38

Corporate Social Responsibility

How we do business is as important as what we do

40

Strength in Depth

Talented leadership with decades of marine experience

42

Good Governance

Supports long-term value creation for our stakeholders

Founders' Message

Inoce Group founders, Alex Vicefield and James Davies, reflect on a decade of rejuvenation as the owners of Davie, while looking ahead to a new era of prosperity for Canada's premier shipbuilder.

Questions for Alex Vicefield

Founder & CEO
Inoce Group

1 Why in 2012 did the Inoce Group acquire Davie?

It was clear to many industry experts at the time that the existing plan to renew the entire federal government's fleet was lacking capacity and it would, whether sooner or later, need Davie's infrastructure, capability and people to deliver on the ambitious program.

We felt that as a group, we were dynamic and nimble enough to take on the task, which called for technical expertise and the right commercial and financial skillsets. The federal and provincial governments, who played a major role in greenlighting our purchase, both agreed. The rest is history.

2 How did Inoce succeed in turning Davie's fortunes around?

Davie people were famously capable shipbuilders and the facility and its production equipment were fantastic. What we brought to the table was insight and expertise from the international shipbuilding industry and a team who could implement systemic changes.

For example, seemingly small changes such as the AVEVA system, which integrates all the processes of the facility into one IT system, have made a world of difference.

3 How much emphasis was placed on developing the Davie corporate culture?

Culture was a major focus for us.



Davie is more than a business. It is a national security asset which ensures that Canada remains a safe and prosperous country for the next generation.

Shipbuilding might be an ancient industry but we can still take a leaf out of the Silicon Valley playbook. We had the very rare chance to reset the business. We were like a 200-year-old start up. We refocused the culture on welfare, training and the health and safety of our people. While this has reaped huge rewards, it did not happen overnight. We had to implement a strategy to restructure and stabilize the business before we could optimize Davie and our people to

focus on key priorities and shape our own future.

4 Was there one "sliding doors" moment that changed Davie's trajectory?

There have been many pivotal moments and our achievements have been the result of the collective efforts of Team Davie. Launching Asterix in 2017 was a highlight for me because it was something I sketched out as an idea one late afternoon. To see it transition from my sketch book to a finished ship was fantastic. It was also the first project we did at Davie from start to finish. When we delivered Canada's largest naval vessel on time and to budget, it was the ultimate proof that all the changes we had made at Davie worked.

5 How important is Davie's inclusion in the National Shipbuilding Strategy?

It was the most significant milestone in eight years of Inoce ownership. It was a proud moment and a credit to everyone at Davie. We always maintained it was in Canada's best interests to have its largest and most capable facility regenerating the federal fleet. But this was far from a foregone conclusion. It took eight years of tireless advocacy, continuous investment in our people, processes and facilities, while delivering complex projects to Canada on time and to budget. We now look forward to being a multi-generational partner with the Canadian government.

6 After eight years under Inoce's ownership, what does the future hold for Davie?

As a team, we have laid the foundations and we're now ready to accelerate our transformation, growth and value creation. 2020 has been pivotal with excellent progress on the NSS and a series of critical projects in the yard or scheduled to start.

Davie has a once-in-a-generation opportunity with a decades-long program of assured work, including newbuild ferries, a roster of icebreakers as well as the maintenance of the navy's patrol frigates.

There will be many more opportunities such as future fleet maintenance, submarines and ferries.

Our vision is to leverage this baseload of work to drive the development of a maritime super cluster to rival Scandinavia.

As one 40-year Davie veteran recently told me, "The future has never been so solid". ■

Questions for James Davies

Inoce Group Founder, President & CEO, Davie Shipbuilding

1 Since 2012, did you ever doubt you'd be able to turn Davie around?

We spent many months in pre-purchase due diligence and it was clear that Davie was Canada's premier facility – a sleeping giant.

We immediately began implementing the changes needed to put Davie back where it belonged among Canada's most prominent industrial assets. We created teams combining the best Canadian and international talent. We invested over \$1bn in the facility, systems and construction programs. We rebuilt our supply chain, re-forged relationships with key stakeholders and, crucially, delivered a roster of best-in-class ships.

The culmination of the past decade's work will be NSS inclusion. Davie will have a guaranteed order book for the next several decades.

2 How would you characterize Davie's strength today as an organization?

We're entering a defining period and definitely our strongest position since WWII. We have a very serious belief that with the highest-possible investment in our infrastructure, and the addition of more capacity, Davie should be the destination to build an array of mission-critical ships such as the replacement for the Victoria Class submarines.

We could also accelerate growth and value creation as a global exporter of specialized mission-critical ships such as general



Davie is entering a defining period and definitely its strongest position since WWII.

purpose frigates and Program Icebreakers.

3 Is Davie particularly suited to building specific categories of vessels?

Depending on the customer's needs, Davie can deliver an array of complex ships, from ferries to frigates.

Canada has recognised Davie's icebreaker capability, which began when we built Canada's first heavy icebreakers in the 1950s. More recently, Canada has awarded Davie icebreaker conversion and newbuild contracts. We have also submitted a proposal as Canada's only qualified facility to build the long-awaited flagship Polar Icebreaker. We would deliver this vessel at a competitive cost and far faster than current government estimates.

Our strategic priority is to replace and sustain Canada's entire icebreaker fleet, which is why we have created the National Icebreaker Centre, Canada's Arctic and Polar hub.

4 How has Davie transformed Canada's federal shipbuilding landscape since 2012?

We've helped reimagine what's possible in defence procurement. Asterix is a great example of how Davie put its collective skills to work for the Royal Canadian Navy.

We challenged conventional wisdom and commercial assumptions. We delivered an innovative, high-quality product with no financial risk to the customer and great value to the taxpayer. All achieved within an unprecedented timeframe. It's a model for future government contracting and a solution other countries are examining with great interest.

5 How would you quantify Davie's economic contribution to Québec and the wider Canadian economy?

It's compelling. Since 2012, our gross economic output to Canada has been close to \$3 billion. Davie's rejuvenation is also closely connected with an ascendant Québec, where our impact on provincial GDP has exceeded \$1.3 billion, while creating or sustaining an annual average of almost 1,900 well paid full-time jobs. We share our success with a Canada-wide supply chain of over 1,300 companies.

As we transition from a project to programmatic way of working to fulfil our long-term order book and growing NSS commitments our value creation will accelerate and expand significantly.

6 What is the next step in confirming Davie's status as Canada's national shipbuilder?

Our third-party analysis for NSS inclusion was completed in February 2020. We are now negotiating the umbrella agreement for the NSS work. It's worth stating that there were some benefits from the NSPS process in 2011, even though Davie was excluded. Since then, we've worked hard to address gaps identified in the previous third-party analysis. This gives us great confidence we can address new issues quickly and efficiently. ■

Who We Are & What We Do

Who We Are

Davie is Canada's premier shipbuilder and a global leader in the delivery of specialist, mission-critical vessels to government and commercial customers. Founded in 1825, Davie is Canada's longest established, largest and highest capacity shipbuilder. Our world-class workforce build and sustain complex ships that enable our customers to protect national and economic security, or fulfil acute business needs.

Davie Strategic Framework

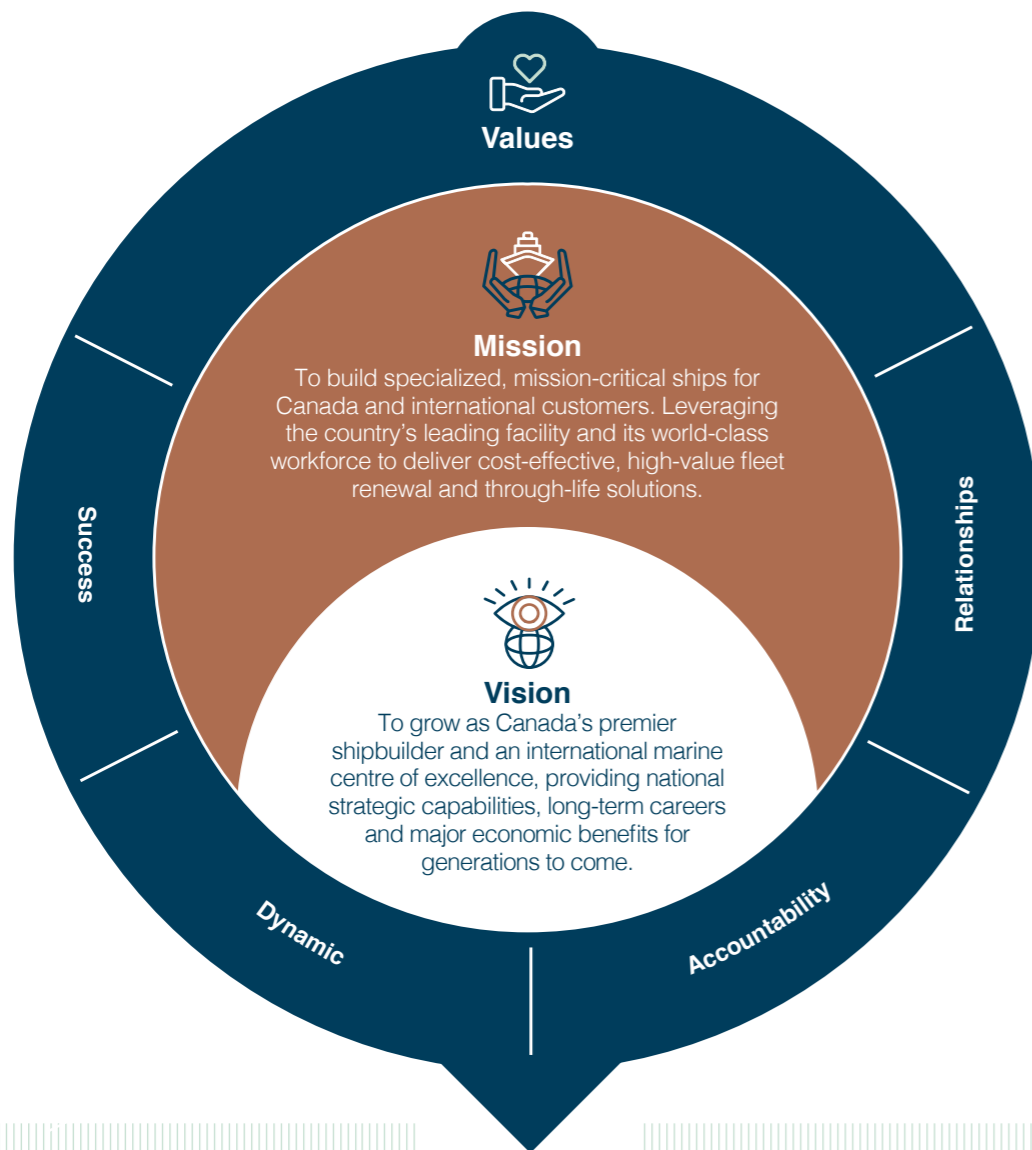

“A key to our success is identifying key trends, challenges and opportunities before our customer does”

Lindsey Kettel, Executive Vice President

What We Do

Build and sustain world-class, specialized, mission-critical ships that enable our customers to protect national and economic security, or fulfill acute business needs.

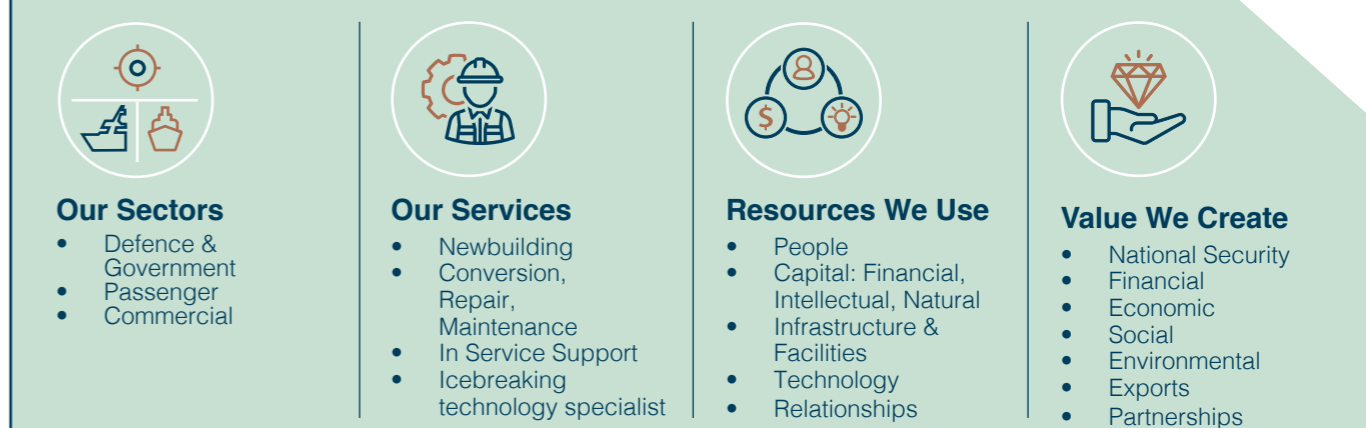

Davie by Numbers

Value Generator

Davie is number one for:



Capacity

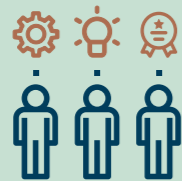

Capability



Delivery



Supply



History

Unrivalled Canada-wide supply chain



\$9.3bn
Orderbook Value

\$20.7bn
Pipeline Opportunities Value

Economic impact¹

Québec

Historic (2012 to 2019) Projected² (2020 to 2040)

Jobs created or sustained **1,890** Up to **3,835**

Gross economic output **\$2.6bn** Up to **\$15.4bn**

Gross domestic product **\$1.3bn** Up to **\$8.3bn**

Canada

Historic (2012 to 2019) Projected (2020 to 2040)

Jobs created or sustained **2,100** Up to **4,270**

Gross economic output **\$2.9bn** Up to **\$17.5bn**

Gross domestic product **\$1.4bn** Up to **\$9.2bn**

1 Davie Shipbuilding Economic & Social Contribution Study © 2020 Deloitte
2 Note: Projected figures depicted are upper ranges based on the following confirmed and potential work programs: Medium, Program and Polar icebreakers, HCWPC, Transport Canada and Quebec ferry programs. This does not take into account all potential future pipeline projects depicted in this publication

Davie Facility
Capacity & Capability

580,000m²
Shipyards area

2 180m + 360m
Drydocks

53,000m²
Workshops

5
Construction berths

900m
Service quays

700+
Total ships delivered by Davie

Major Projects Completed 2012-2020

Subsea Construction Vessel	
Dual Fuel Ferry	
Resolve Class Combat Support Ship	
Coast Guard Vessel Life Extension	
Orderbook Highlights	
Medium Icebreaker Conversion	
Patrol Frigate Maintenance	
Program Icebreaker Newbuild	
Federal Ferry Newbuild	

Pipeline Opportunity Highlights

Polar Icebreaker Newbuild	
Submarine Maintenance (VISSC2)	
Second Resolve Class Combat Support Ship	
Auxiliary Vessel Maintenance (MWAVII)	
Coast Guard Vessel Life Extension Program	

~ \$500m
Expected new investment

~ 40%
of all Québec shipbuilding and repair industry workers were employed by Davie in 2019

\$1bn+
invested in construction programs and the Davie facility since 2012



Davie Timeline: 2012-2040

“ We have a once-in-a-generation opportunity, with Canada set to invest an estimated \$50 to \$60 billion, refitting and supporting its fleet of existing and new vessels. ”

Spencer Fraser,
Business Development Director, Inoce Group

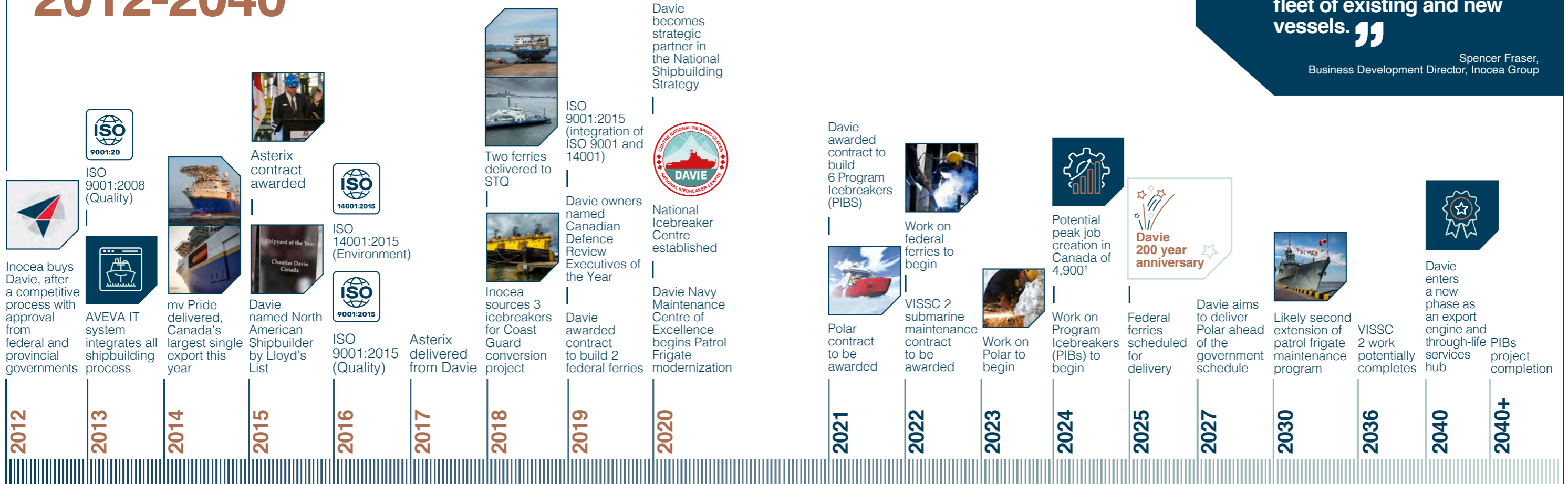

¹Davie Shipbuilding Economic and Social Contribution Study © 2020 Deloitte *Global Logistics, Aviation & Medical Support Platform

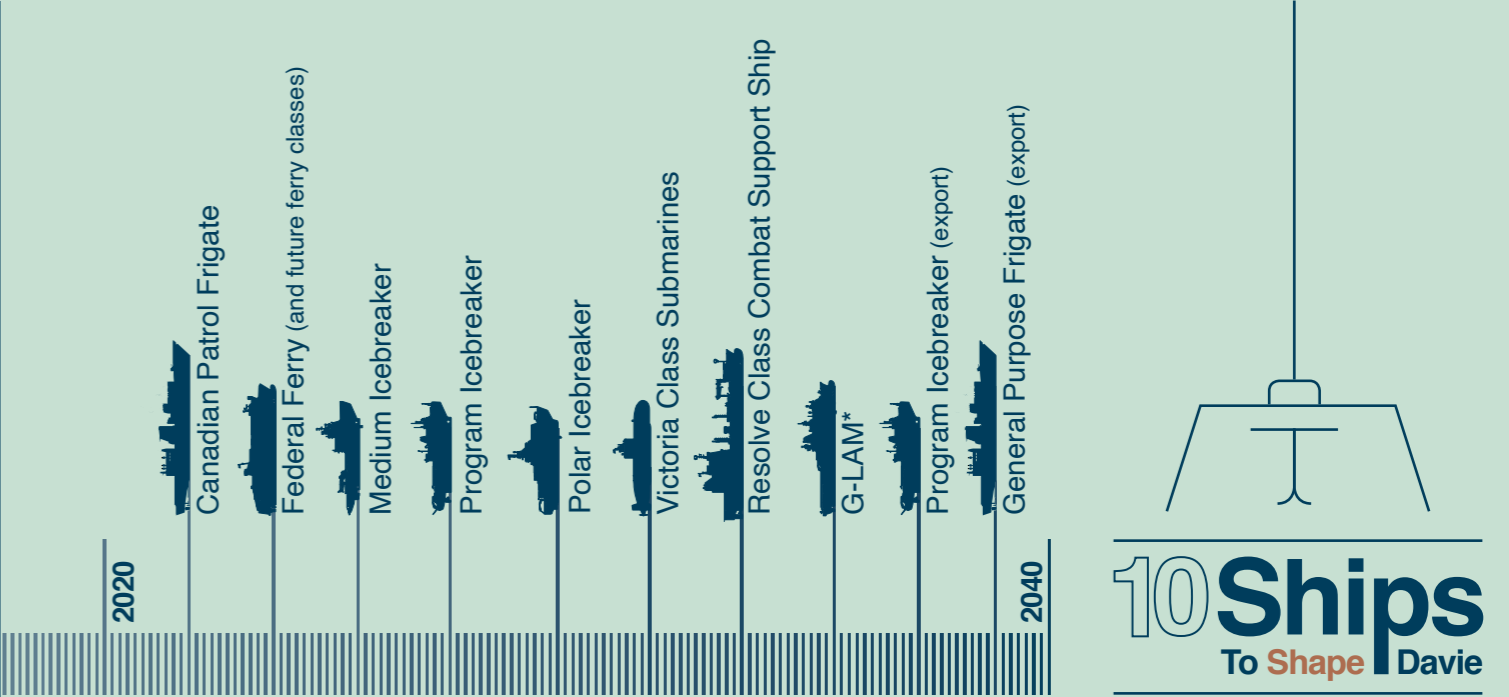
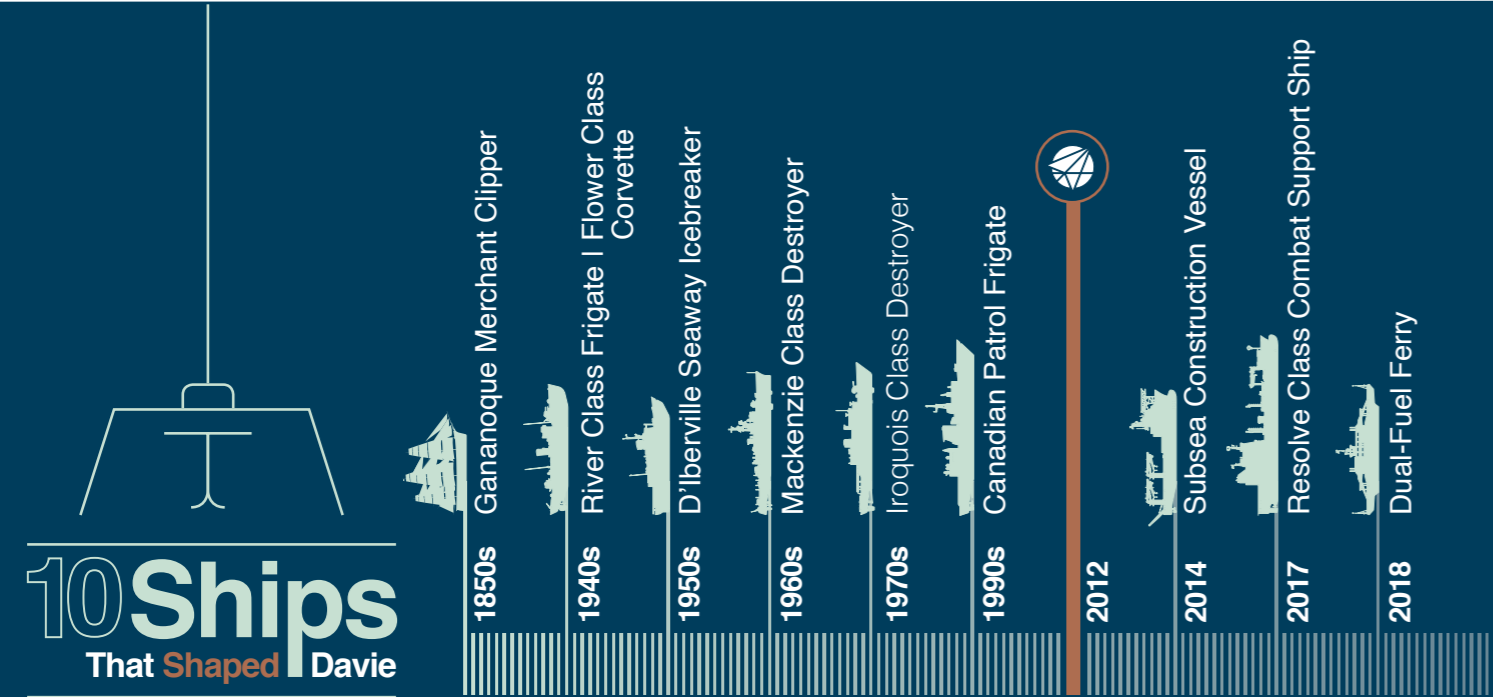

Davie Highlights



The Resolve-Class Combat Support Ship, m/v Asterix, was delivered in 2017 by Davie to Federal Fleet Services for a long-term support services contract with the Royal Canadian Navy

Generational Opportunity: The NSS Explained

Becoming a partner in the National Shipbuilding Strategy (NSS) and a credit to everyone at Davie. Our role in Canada's largest-ever marine and defence procurement is explained here.

Mid 1990s Aging Federal Fleet

Canada's federal shipbuilding program was in decline due to decades of under-investment, capacity and capability shortfalls, spiralling costs and multi-year delays. This was despite the pressing need to renew a fleet with 96% of ships aged over 30 years.

2011 Davie Shortlisted for NSPS

Davie was shortlisted as technically compliant to become an NSPS partner. Despite having 50% of Canada's capacity available and ready to build ships, it was not chosen due to its poor financial position at the time. Instead, agreements were awarded valued at \$38 billion, rising to over \$70 billion, to two smaller facilities. Industry experts correctly contended that excluding Davie's capacity, infrastructure and people meant Canada would be unable to deliver such an ambitious construction program.

2010 A New Approach

The Government of Canada launched the "National Shipbuilding Procurement Strategy" (NSPS), the largest such sourcing arrangement in Canadian history.

Core objectives:

-  Replace navy and coast guard fleets to support national and economic security
-  Create sustainable jobs and economic growth
-  Support a vibrant maritime sector

NSPS pillars for combat and non-combat construction programs:

-  Large vessel construction
-  Small vessel construction
-  Repair, refit and maintenance work

2012-2019 Davie's Voyage to NSS Inclusion

Inoceca purchased and reopened Davie for business in 2012 and began exporting complex vessels to the oil and gas market, refitting Canada's icebreakers and delivering the Resolve Class Combat Support Ship m/v Asterix, the largest naval vessel ever delivered from a Canadian facility. In 2019, as a result of insufficient capacity and pressing operational requirements, the Government of Canada initiated a competition to add a third shipbuilder to what was now known as the National Shipbuilding Strategy (NSS).

2020-2040+ Davie to Drive Refreshed NSS

Davie pre-qualified under the large vessel construction pillar to become a partner under the NSS. Davie would initially deliver icebreakers. No other candidates were shortlisted. Davie's third-party analysis for NSS inclusion was completed in February 2020, with the next step being the negotiation of an Umbrella Agreement.

“ This announcement is a critical milestone in how we are able to adapt the strategy to meet Canada's evolving federal shipbuilding needs, all while ensuring the members of the Coast Guard have the equipment they need to do their important work ”

The Honourable Anita Anand, Minister of Public Services and Procurement, on the announcement in December 2019 of Davie's pre qualification as third strategic partner in the NSS

NSS partners

NSS shipbuilding partners	Federal Departments
Davie (Québec)	Fisheries and Oceans
Irving (Nova Scotia)	National Defence
Seaspan (British Columbia)	Innovation Science & Economic Development
	Public Services & Procurement

NSS Benefits

-  Guaranteed work at Davie until 2040+
-  Transition from project-based to programmatic way of working
-  High value federal contracts
-  Thousands of sustainable jobs created
-  Growth of Canada-wide supply chain, including thousands of SMEs
-  Major economic contributions to Québec and Canada through ITB contributions
-  Cost and productivity benefits of NSS gap closure investments
-  Drive development of vibrant Maritime Cluster aligned with NSS Value Proposition
-  Establish Arctic Centre of Excellence
-  International export potential for mission-critical ships

New Icebreaker Fleet

6
newbuild Program Icebreakers (PIBs)

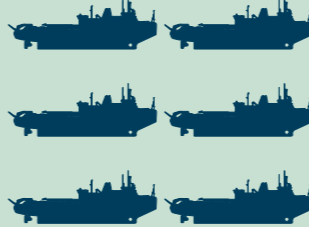

Davie Potential Future Programs

- Newbuild Polar Icebreakers 
- Additional Resolve Class Combat Support Ship 
- Newbuild submarines 
- Global Logistics, Aviation & Medical Support Platform 

Davie Potential Exportable Programs

- Program Icebreaker (PIBe) 
- General Purpose Frigate (GPFfe) 
- Combat Support Vessel 

Pride of Québec

Proudly Québécois since 1825, Davie is partnering with the Province to ensure their rich shared maritime heritage feeds a bright future to 2040, and beyond.

Davie is synonymous with the rich maritime heritage of Québec, the company's home for almost 200 years. Strategically located along the St Lawrence River in Lévis, Davie employs thousands of Québécois and contributes billions of dollars to Canada's second-largest economy.

Davie is proudly Québécois. The province's economy, environment and social fabric are intertwined with its rivers, lakes and oceans. In fact, Québec's growing Blue Economy is anchored by Davie's shipbuilding activities as well as the ports, resource exploration, maritime and coastal tourism.

Davie shares the Québec government's vision for an economically powerful nation which asserts its unique identity. Québec has undergone tremendous changes over the past decade and prior to the COVID-19 crisis was among Canada's fastest-growing economies. Davie is committed to supporting the COVID-19 recovery and ensuring prosperity is rapidly restored to Québec.

The National Shipbuilding Strategy (NSS) will be key to recovery as it provides long-term, stable business opportunities. As an NSS partner, Davie has a pipeline of work until the 2040s. This is breathing new life into Davie and thousands of its Québec-based suppliers and partners.

Suppliers are integral to Davie's success. The independent Davie Suppliers Association was founded in 2018. Since then membership has increased strongly across Québec. The Association gives Davie suppliers a single voice and strengthens supply chains right across Canada (see interview below with Pierre Drapeau).



Davie is contributing to Québec's long-term prosperity and inspiring a new generation of Québécois entrepreneurs, industrialists and shipbuilders.

Frederik Boisvert, Vice President, Public Affairs



Quick Q&A



Pierre Drapeau
Vice President,
Davie Suppliers
Association

1 How would you judge the progress of the Davie Suppliers Association?

It has been a great success story for Québec and Canada. It was only formed in early 2018, but already has a Canada-wide membership of several hundred, with a large proportion of dynamic SMEs from across Québec's 13 regions.

2 For the suppliers, what makes Davie different compared to other companies?

Over the past decade, under Inoce's ownership, Davie has consistently delivered complex, mission-critical ships to Canada. From the outset, the

owners understood that the working relationship with the suppliers was as important as their employees, capabilities, systems and equipment.

3 Is there a key difference with other supplier networks?

It's a partnership. Suppliers are loyal to Davie as they are respected and well paid. This was true even when Davie was excluded from the NSS.

The Association's strong and united voice in support of Davie's NSS inclusion had a significant impact. Our members are now well positioned to benefit from contracts Davie secures as it rebuilds Canada's fleet. Also, working with Davie has been a gateway to export opportunities for many Québec companies.

4 What is next for the Association?

To continue our engagement with all new suppliers, of course. We need to build on the regional committees set up in key regions last year by including all important manufacturers. We are also looking at a new recognition mechanism. Davie would formally show gratitude to its suppliers, which would strengthen the sense of belonging and pride among our members.

We want Davie to be the pride of Québec – a reliable and committed partner delivering on promises, with suppliers being well rewarded and many more projects to come.

Centres of Excellence

Davie is making Québec a global destination for a range of services and capabilities. For example, Davie's "National Icebreaker Centre" is renewing Canada's icebreaker fleet and becoming a global hub for Arctic expertise. This will be a key pillar of the St Lawrence Maritime Cluster, creating long-term economic value and inspiring the next generation of Québécois entrepreneurs, industrialists and shipbuilders.

NSS Cluster

The NSS emphasises the development of a vibrant shipbuilding cluster by strengthening links between Davie, and other major contractors, and suppliers, communities and research institutions.

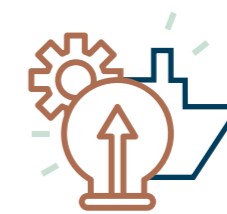

Interconnected Maritime Clusters

Davie is playing a leading role in the creation and development of world-class interconnected clusters to promote sustainable maritime growth benefitting Québec and Canada.

Québec Maritime Strategy

Davie champions the Québec Maritime Strategy, which seeks to foster sustainable growth through a powerful industry cluster to benefit all Québécois. The strategy seeks to revitalize regional economies by promoting the creation of up to 30,000 new jobs and investment of \$9 billion by 2030.

The St. Lawrence Maritime Cluster

Davie, alongside Québec shipbuilders, has created the St. Lawrence Maritime Cluster Corporation (SLMCC) to promote innovation, economic competitiveness and R&D within the Québec shipbuilding and ship repair industries. The SLMCC aims to expand to the Great Lakes to facilitate greater integration of the Central Canada marine industry.

Ocean Super Cluster

Davie supports Canada's Ocean Supercluster (OSC) – one of five launched in 2018. Including shipping and defence, the OSC aims to position Canada as the global leader in sustainable ocean innovation.



Asterix: Force Multiplier

Project Resolve, initiated by Davie in 2015, became a mandate from the Canadian Government to convert a 1,700 TEU commercial container ship into a class-leading combat support ship. The result was Asterix, the RCN's first Resolve-Class Combat Support Ship. It has been a resounding success since deployment in 2017 ready to support combat operations, humanitarian assistance and disaster relief worldwide.

Asterix Broke New Ground on Multiple Levels:

- ✓ Converted to a military-specified support ship in a record 18 months
- ✓ 26,000 tonnes, the largest naval vessel ever delivered by a Canadian shipbuilder
- ✓ Delivered at 25% of the cost of the proposed Joint Supply Ship
- ✓ Financed privately by Davie parent, Inoce, with no risk or cost to Canada
- ✓ Owned by Davie's sister company Federal Fleet Services (FFS)
- ✓ Operated with a combination of FFS and the Royal Canadian Navy crew



Medical and humanitarian facilities for up to 350 people

Dry and refrigerated containerized storage



Helicopter deck and hangar for support and maintenance

Integrated navigation, machinery and damage control system



Shore connections to provide power and water

Replenishment at sea – NATO Stream



“Project Resolve was an incredibly innovative approach that led to Asterix - an amazing ship that would enhance any navy's ability to sustain in all theatres of operation.”

Gilles Couturier, CEO FFS and retired Rear Admiral Royal Canadian Navy

CTF150
Attached to counter-terrorist taskforce in Arabian Sea



502 day record deployment completed in August 2019



30,811,000 litres of ship fuel delivered



3 Critical global operations.
Neon (N. Korea); Artemis (Iran, Somalia); Projection (Asia-Pacific)

Record 502-day deployment

40 allied warships replenished



7x AROUND THE WORD

150,721 nautical miles travelled

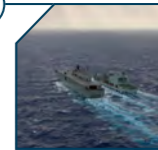

197 supply operations



12 international navies supported



Greenest Naval Ship Ever Built in Canada



Asterix was the first naval support vessel to join the Green Marine, the environmental certification program. It has Québec company Terragon's micro auto gasification system (MAGS)—world-leading environmentally safe technology for the conversion of refuse into thermal energy for the ship's use. MAGS is also rated for the Arctic.

Canadian Innovation

Asterix is equipped with world-class Canadian military technology – enabling small and medium-sized enterprises to seek and secure export opportunities.



Resolve Class Export Potential

This multi-functional design has attracted the attention of international navies, with ongoing discussions on the potential to build a second Resolve Class Ship.



1,400

Canadians built and delivered Asterix in a record 18 months

6,000

tonnes of steel work for Asterix was completed in under a year

85%

of the Asterix project was conducted in Canada by Canadian suppliers

Innovation Incubator

A key factor in Davie's success has been its ability to continuously identify the future needs of our clients and to research and develop the best-possible solutions to meet them.

Our drive to identify, meet and even exceed our customers' future needs is relentless. As Canada's leader in advanced, specialized vessel construction, we mine the world for the latest technological advances while keeping a close check on developments in manufacturing, regulation, finance, geopolitics and the environment. We protect our intellectual property, while maximizing the commercialization potential and exportability of our work. We research and develop solutions in close collaboration with our customers, our own highly skilled teams and strategic partners.



Our drive to identify, meet and even exceed our customers' future needs is relentless.

Ron Pearson, VP Engineering

Submarine-X

Canada's aging submarines have spent less and less time at sea, notably with zero hours in 2019. With the fleet reaching an advanced age, in addition to seeking to keep Canada's existing submarines operationally effective, Davie is exploring partnerships with global leaders to provide a build-in Canada solution for the submarine of the future.

PIB (for export)

Davie is Canada's only facility with the capacity, capability and experience to deliver mission-critical icebreaking platforms for Canada and, ultimately, for export. The six cutting-edge heavy Program Icebreakers (PIBs) Davie will build under the NSS will be a testament to Canadian ingenuity and expertise. The PIB(e) will be designed to meet the current and far future needs of international customers.

Focus areas include



Design & Engineering



In-service Support



Manufacturing

Global Logistics, Aviation and Medical Support Platform (G-LAM)

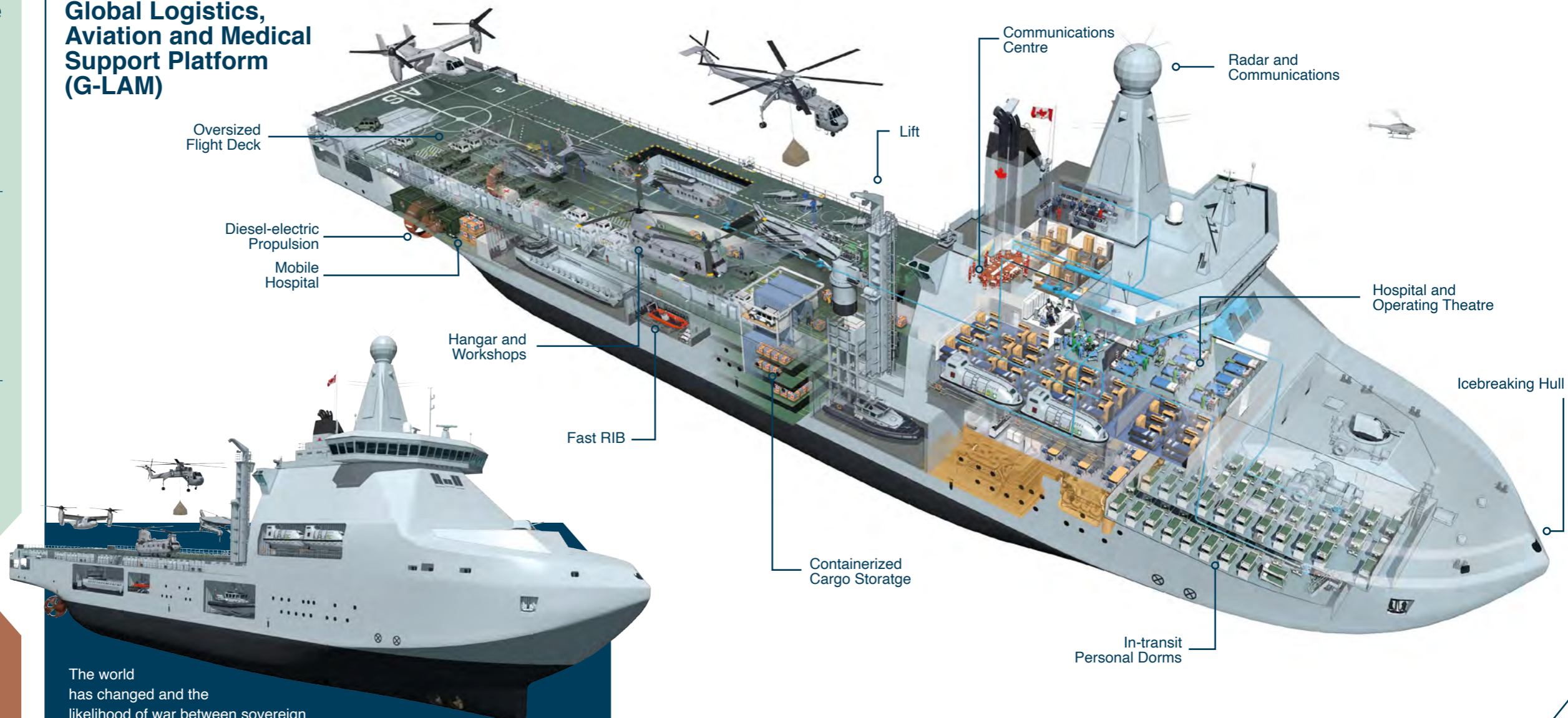

CASFI

The Canadian Australian Strategic Firefighting Initiative (CASFI) is a full-service solution to strategically enhance both Canada's and Australia's extant aerial firefighting capabilities. As a privately financed solution, it draws on the proven expertise of both Canadian leading aircraft manufacturers and Davie to provide the required planes and a bespoke transportation vessel to move the capability between the two countries between the two fire-risk seasons.

The world has changed and the likelihood of war between sovereign states, particularly at sea, is ever diminishing. What is more commonplace today are counter-terrorist, counter-insurgency and humanitarian and disaster relief operations. And while frigates have historically been the most utilized platform in the naval fleet, it is the multipurpose ships which are seeing most service in global navies. Davie's G-LAM program is a multi-purpose support vessel designed to best support the Canadian government's agenda in a transforming global geopolitical landscape – prioritizing peacekeeping, humanitarian assistance and disaster relief efforts.

GPFe (for export)

Davie is tapping into an emerging global trend for versatile, cost-effective warship design. With decades of experience delivering Canada's largest combat vessels, Davie is assessing low-cost, fit for purpose frigate designs which could be built for export. Davie's multi-role GPFe would have peacekeeping, humanitarian and combat capabilities. This could create a sustainable export for Canadian industry.

Next Generation Shipbuilding Facility

Davie is already Canada's longest-established, largest and most capable shipbuilder. Our continuous improvement program has ensured Davie thrives as Canada's only mega-yard and a multi-generational partner under the National Shipbuilding Strategy.



Davie is investing in state-of-the-art equipment, systems and processes

Work underway on the multi-million dollar upgrade to the Lorne Dock

Davie is a unique and indispensable national security asset to Canada, and many international customers. Today, our facility, by far the country's largest and most capable, is preparing for life as a multi-generational partner to the Canadian government, rejuvenating the federal fleet under the National Shipbuilding Strategy (NSS). This will see Davie's National Icebreaker Centre build a new fleet for the Canadian Coast Guard (CCG).

Davie's scale and capability are unprecedented. We can, for example, fabricate up to 9,000 tonnes of steel per year supported by our manufacturing shops, the industry's best workforce, and a Canada-wide supply chain. Our 351-metre Champlain Dock can already accommodate the largest Canadian vessels. Davie previously built a 200-metre ship on our existing slipways, which have also been used to erect large blocks and launch hulls.

Over the past decade, Davie has made significant investments in upgrading the facility. This includes new cutting-edge ship production equipment and machinery to new office facilities to a new Enterprise Resource Planning (ERP) system. Most recently, Davie made multi-million-dollar enhancements to the Lorne Dock to accommodate the long-term naval Frigate maintenance program and for subsequent in-service support contracts.

As part of the NSS process, we plan to invest ~\$500m to ensure Davie, as Canada's premier shipbuilder, remains an efficient and cost-effective constructor of the most complex, mission-critical vessels for our customers.



Davie will continue investing to ensure we remain an efficient and cost effective constructor of complex, mission-critical vessels.

Richard Allie, Vice President, Operations

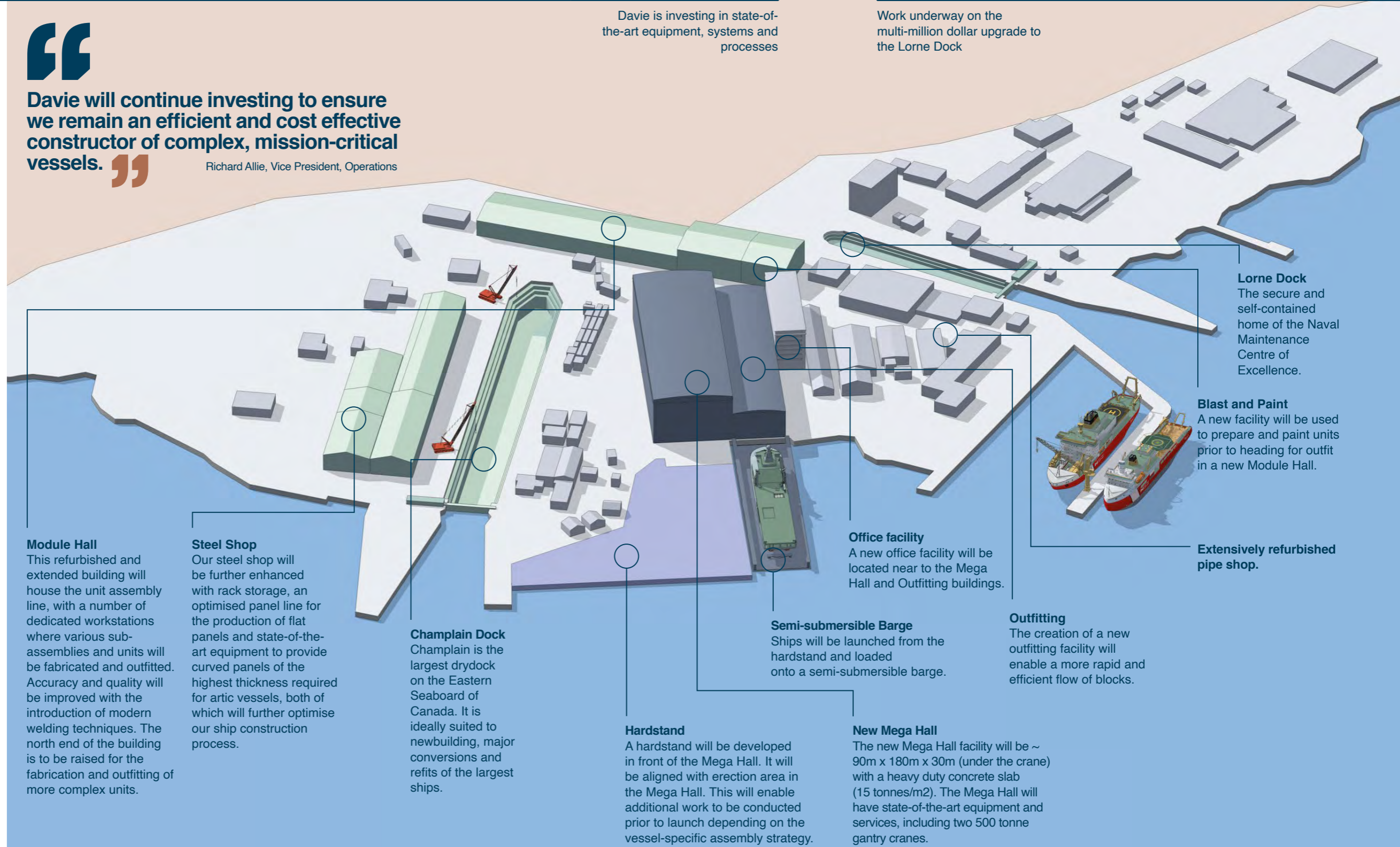

Module Hall
This refurbished and extended building will house the unit assembly line, with a number of dedicated workstations where various sub-assemblies and units will be fabricated and outfitted. Accuracy and quality will be improved with the introduction of modern welding techniques. The north end of the building is to be raised for the fabrication and outfitting of more complex units.

Steel Shop
Our steel shop will be further enhanced with rack storage, an optimised panel line for the production of flat panels and state-of-the-art equipment to provide curved panels of the highest thickness required for artic vessels, both of which will further optimise our ship construction process.

Champlain Dock
Champlain is the largest drydock on the Eastern Seaboard of Canada. It is ideally suited to newbuilding, major conversions and refits of the largest ships.

Hardstand
A hardstand will be developed in front of the Mega Hall. It will be aligned with erection area in the Mega Hall. This will enable additional work to be conducted prior to launch depending on the vessel-specific assembly strategy.

Office facility
A new office facility will be located near to the Mega Hall and Outfitting buildings.

Semi-submersible Barge
Ships will be launched from the hardstand and loaded onto a semi-submersible barge.

New Mega Hall
The new Mega Hall facility will be ~ 90m x 180m x 30m (under the crane) with a heavy duty concrete slab (15 tonnes/m²). The Mega Hall will have state-of-the-art equipment and services, including two 500 tonne gantry cranes.

Outfitting
The creation of a new outfitting facility will enable a more rapid and efficient flow of blocks.

Blast and Paint
A new facility will be used to prepare and paint units prior to heading for outfit in a new Module Hall.

Extensively refurbished pipe shop.

Lorne Dock
The secure and self-contained home of the Naval Maintenance Centre of Excellence.

National Icebreaker Centre

The need for a modern, versatile and efficient icebreaker fleet has never been greater. Davie is home to Canada's National Icebreaker Centre and has been a global leader in the delivery of these increasingly mission-critical vessels for 70 years.



Davie is Canada's premier icebreaker constructor. It has been a global leader in this specialised technology since delivering CCGS D'Iberville in 1952, which was Canada's largest and most powerful icebreaker.

Davie has over the past seven years completed the extensive upgrade and refit of several of the Canadian Coast Guard's (CCG) largest icebreakers, including being the exclusive repair base for Canada's existing heavy icebreaker, CCGS Louis St Laurent. In 2018, Davie also delivered CCGS Captain Molly Kool, the first new icebreaking asset for the CCG in more than 25 years.

Today, with a multi-vessel, multi-year order book, Davie continues to be at the forefront of the design, engineering and construction of an emerging generation of multifunctional icebreakers.

Davie is Canada's National Icebreaker Centre



Canada's polar icebreaker partner of choice today and for the future



Multi-ship icebreaker orderbook as National Shipbuilding Strategy partner



7 decades of cutting-edge polar icebreaker expertise in newbuilding and maintenance



Track record of delivering mission-critical ships and polar icebreakers to Canada



Strategic location: Eastern Canada, St Lawrence, Great Lakes, Atlantic, Arctic



World-class workforce and pan-Canada supply chain of over 1,300 companies



Only facility with capacity and experience to build Canada's entire icebreaker fleet



Future world leader and exporter of Canadian polar icebreaker technology



Economic engine for Québec and Canada

Multi-ship, multi-year orderbook and potential projects

3 converted Medium Icebreakers (MIBs)



The Tor Viking and Balder Viking are currently being converted by Davie for the CCG as medium icebreakers. CCGS Captain Molly Kool was successfully delivered in 2018.

6 new building Program Icebreakers (PIBs)



Under the National Shipbuilding Strategy (NSS), Davie will construct six heavy Program Icebreakers (PIBs) to provide the CCG with the capability and capacity to meet current and far future needs. Work on the PIBs is expected to begin in 2024 and complete in 2041.

1-2 Polar Icebreakers



The project to build 1-2 Polar icebreakers could be added to Davie's NSS order book. Davie can deliver the first polar, the replacement for the CCGS Louis S. St Laurent, ahead of the current government schedule.



“Davie is building Canada's new icebreaker fleet and rapidly becoming a global hub for Arctic expertise”

John Schmidt, Sr. Vice President, Commercial & Government Programs

Economic Engine

With the support of the Québec Government, Davie is a champion of the Québec Maritime Cluster to make Québec a global destination for a wide range of maritime activities.

Davie is also a major economic contributor to both Québec and Canada. Since 2012, Davie has generated gross economic output of \$2.9bn. In that time it has created or sustained 2,100 well-paid full time jobs. Davie also partners and shares its success with over 1,300 suppliers across 10 provinces. The National Icebreaker Centre will add guaranteed high-value work into the 2040s as well as providing important export opportunities for the Canadian economy.

Future focus

The need for a modern, versatile and efficient icebreaker fleet has never been greater. These unique ships benefit all Canadians by helping to protect and enable the economy, security, sovereignty and the marine environment.

Climate change means the Arctic region is increasingly critical to international political and commercial strategies. As sea ice declines, transpolar trade routes will become ever more navigable and the exploitation of natural resources in the Arctic will inevitably increase. With it, will come significant risks. State-of-the-art icebreakers are critical for ensuring the safety of navigation and the environment as the Arctic increasingly becomes a hive of federal, academic and commercial activity.



Program Icebreaker highlights

- The PIBs will be the backbone of the CCG's icebreaker fleet
- The PIBs will be able to operate in severe ice conditions and support Arctic missions during winter and summer
- The PIBs will be capable of maintaining 3 knots continuous forward progress in 1.4 meters of ice
- The PIBs will have a range of approximately 20,000 nautical miles at a cruising speed of 12 knots without refuelling

Through Life Partner

Through Life Solutions (TLS) has been a major area of focus and remains a growth area for Davie, which is Canada's only full-service provider.

At Davie, sustaining and ensuring optimum performance of a ship through its long life is as important as building the vessel.

Through Life Solutions (TLS) is a major area of focus and growth for Davie. Canada is set to spend an estimated \$50 to \$60 billion over the next 30 years maintaining, refitting and supporting its fleet of existing and new vessels. This will create thousands of jobs and sustain a Canada-wide supply chain.

Davie's investment in our facility and the continuous improvement of our capabilities has strengthened our position as Canada's only full-service provider. We are a one-stop shop from concept, design, construction, conversion, repair, maintenance and sustainment through to end of life.

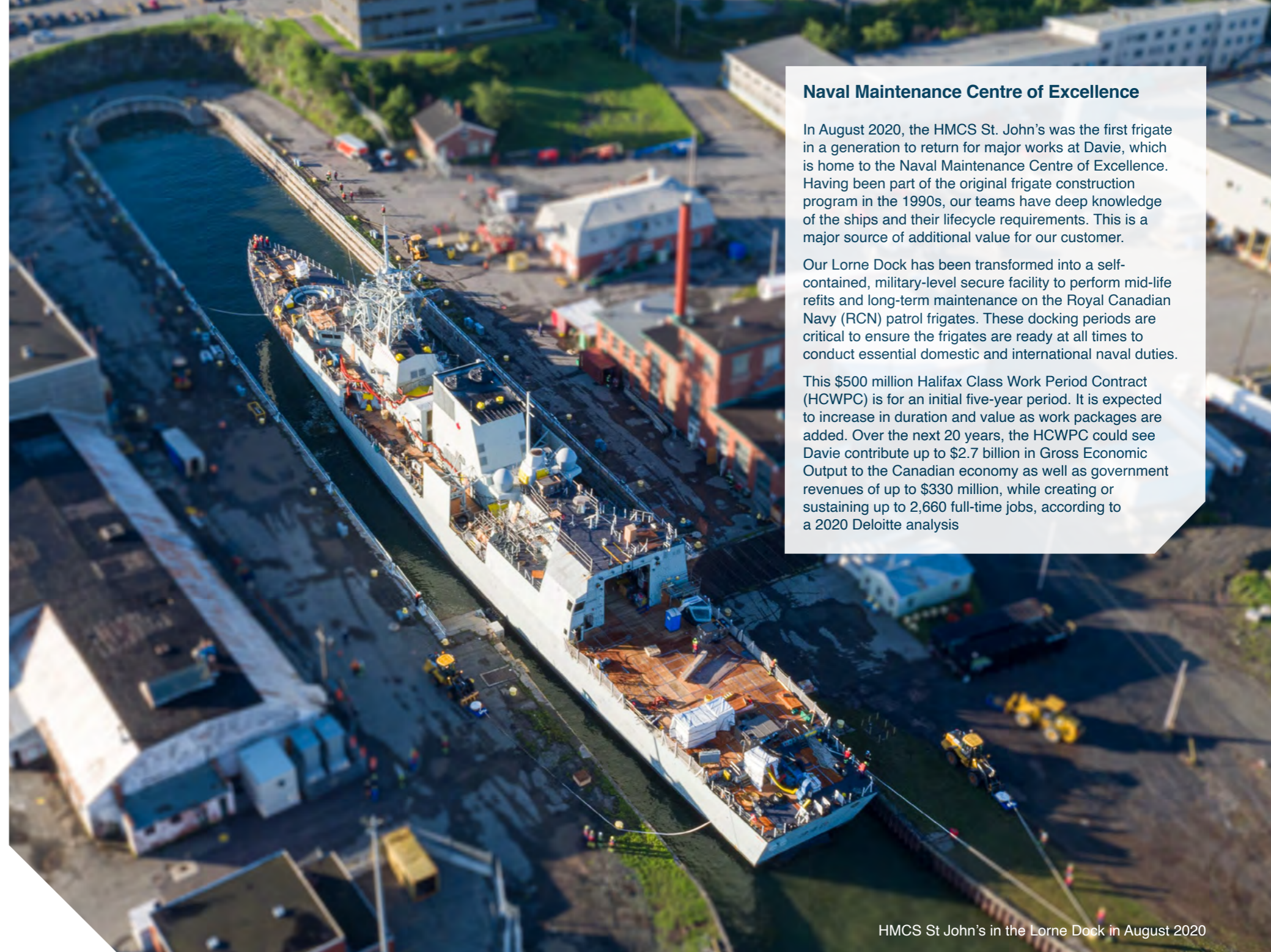
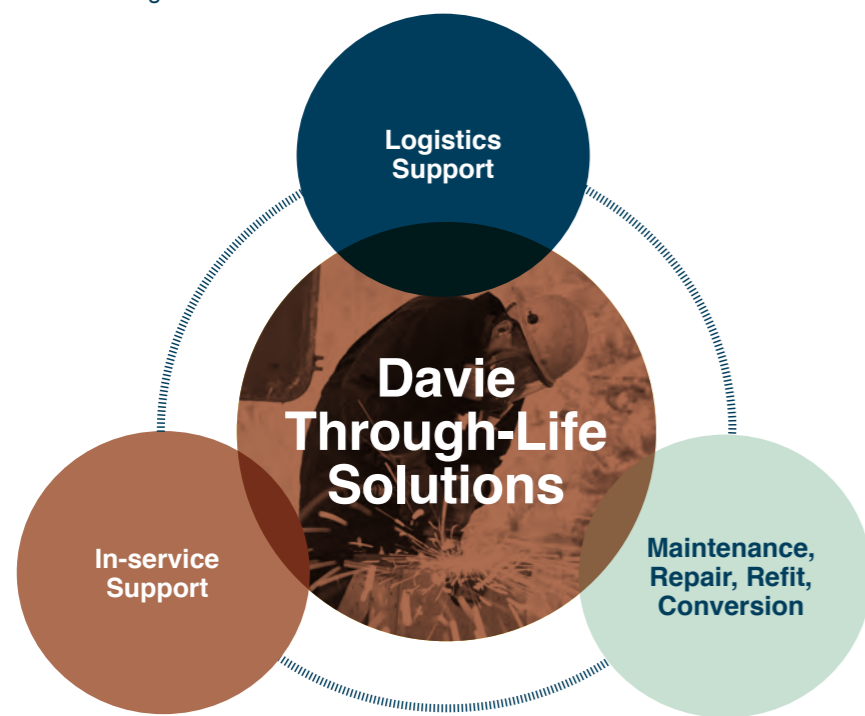

Naval Maintenance Centre of Excellence

In August 2020, the HMCS St. John's was the first frigate in a generation to return for major works at Davie, which is home to the Naval Maintenance Centre of Excellence. Having been part of the original frigate construction program in the 1990s, our teams have deep knowledge of the ships and their lifecycle requirements. This is a major source of additional value for our customer.

Our Lorne Dock has been transformed into a self-contained, military-level secure facility to perform mid-life refits and long-term maintenance on the Royal Canadian Navy (RCN) patrol frigates. These docking periods are critical to ensure the frigates are ready at all times to conduct essential domestic and international naval duties.

This \$500 million Halifax Class Work Period Contract (HCWPC) is for an initial five-year period. It is expected to increase in duration and value as work packages are added. Over the next 20 years, the HCWPC could see Davie contribute up to \$2.7 billion in Gross Economic Output to the Canadian economy as well as government revenues of up to \$330 million, while creating or sustaining up to 2,660 full-time jobs, according to a 2020 Deloitte analysis

HMCS St John's in the Lorne Dock in August 2020

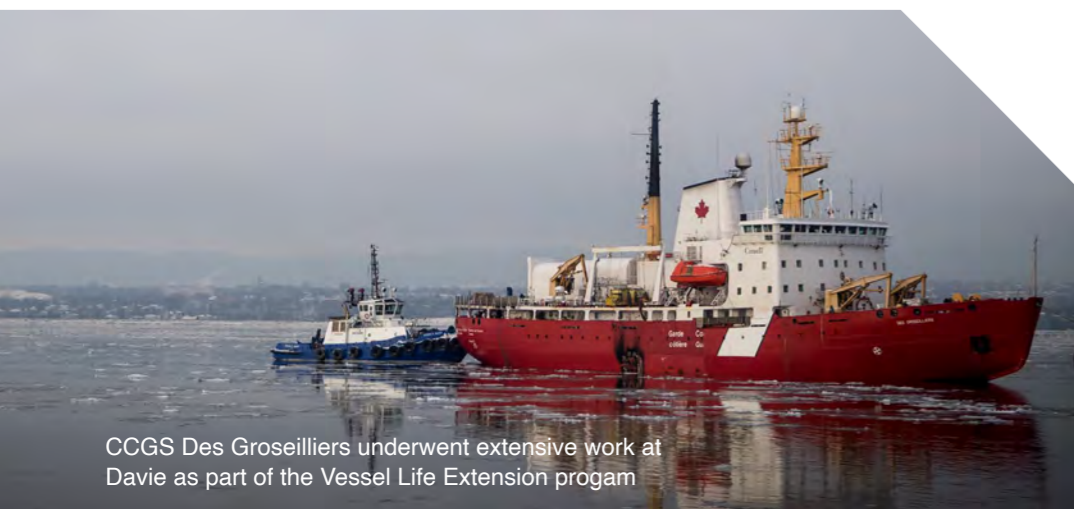

COGS Des Groseilliers underwent extensive work at Davie as part of the Vessel Life Extension program



HMCS St John's docked in the Lorne Dock in July 2020

Vessel Life Extension Programs

The Canadian Coast Guard has a multi-ship Vessel Life Extension (VLE) Program for three aging Type 1100 icebreakers, which typically operate year round performing a range of tasks and support services primary on Canada's East Coast. Work is scheduled to begin from 2022 on one vessel per year. The value of the contract of each ship is in the \$75 million range.

In Service Support Contracts

VISSC II

Davie, as a leading member of the Canadian Submarine Alliance, is also among the shortlisted bidders for the In Service Support Contract for Canada's Victoria Class diesel-electric submarines, which were acquired from the UK in 1998. The VISSC fleet has a planned operational life until 2035. Davie and its partners will draw on their collective experience and capabilities to enhance Canada's sustainment capabilities for these highly strategic national security assets. The VISSC II is a 15-year contract worth \$3 billion and is expected to be awarded in 2022.

MWAV

Davie has been shortlisted, in a consortium with Serco, for the Minor Warship Auxiliary Vessel In-Service Support Contract (MWAV ISSC). The MWAV VI is 15-year contract worth \$1.8 billion, which covers the maintenance management of the in-service support for more than 100 RCN auxiliary support vessels.

Davie People & Culture



HMCS St John's enters Lorne
Drydock in August 2020

Davie Spirit for a New Generation

Davie is a major employer in Québec and Canada, whose people and culture are among its strongest attributes. With decades of work ahead, Davie aims to be a destination for the brightest and best talent.

People Power Our Business

Since 2012, Davie has created or sustained an average of 2,100 well-paid full-time jobs and provided total economic output to Canada of close to \$3 billion. In that time, the total earnings and supplementary income of employees totalled \$910 million and Davie paid \$330 million in taxes and other government revenues¹. Today, with decades of work ahead, our contribution as a major employer will be unprecedented in Davie's history.

Investing in and developing our people is a strategic priority. As a partner in the National Shipbuilding Strategy (NSS), Davie will transition from a project orientation to a programmatic way of working. We will increasingly be a destination for varied and rewarding careers.

A key challenge will be recruiting the many people needed to deliver our growing book of business. In this context, nurturing positive and forward-looking relationships between Davie, our employees and the unions will continue to be a top priority.

We are also prioritising the identification and preparation of potential leaders for succession in key roles, which will be

critical to our continued success. Key ongoing initiatives include a company-wide succession planning exercise.

Davie is committed to training, skills enhancements and professional development for employees at all levels. This will include structured programs, on-the-job training, participation in special project and role rotations.

Our world-class services and products are created and delivered to our customers by a diverse workforce. We actively seek talent from Québec, Canada, and around the world.

With our unique facility, Davie develops and nurtures working relationships with a growing number of educational institutions, including maritime training institutions such as Institut maritime du Québec and colleges and universities including Cégeps and Laval University MBA.

Going forward, our unique Davie Spirit will continue to be at the heart of our corporate culture inspiring our people to reach their full potential and maximise their contribution to our success in the years ahead.



As a partner in the National Shipbuilding Strategy, Davie will increasingly be a destination for a range of varied and rewarding careers

Stephen O'Brien, Chief Operating Officer and Managing Director



The "Davie Spirit" is our North Star. This unique sense of collective pride, passion and commitment is a source of sustainable competitive advantage. It is encapsulated by an indomitable can-do attitude, driving us to deliver the best work even in the face of great challenges. The Davie Spirit breaks down barriers and hierarchies to ensure opinions and ideas are welcomed from everywhere and everyone in our organization.



Strategic Priorities & Initiatives

It is Davie's people who drive our success and confirm our standing among Québec's and Canada's leading industrial companies. It is our strategic priority to invest in our people and strengthen our culture.

Investing in Our People – Create Stimulating & Rewarding Careers

- Proactive Recruitment – regional, provincial, national, international
- Dynamic Succession Planning and Career Development
- Comprehensive Training and Development
- Reward and Recognize Achievements and Performance

Strengthening Our Culture – An Engaged Workforce & Engaging Workplace

- We believe in an inclusive culture built on fairness, merit and respect that helps our people reach their potential. Our people personify our core values: Success | Dynamic | Accountability | Relationships
- Reinforcing our Purpose to focus on why we do what we do, to inspire, motivate and instill a sense of ownership in building a prosperous future together
- At Davie, working safely is paramount and dovetails with achieving quality and productivity; commitments which extend to all employees, subcontractors, supplies and partners



Mariska Potvin-Chretien at work on the CCGS Jean Goodwill MIB conversion.

Davie believes in an inclusive culture and actively seek talent from Québec, Canada and around the world.

Quick Q&A



Questions for Benoit Chasse
Vice President
Human Resources

1 What is your vision for the development of Davie's people and culture?

We have a tremendous base to build from – regionally, provincially and nationally. We intend to be recognized among Québec and Canada's employers of choice. A company where people can thrive, make a difference and achieve a great sense of purpose with

Canada's premier shipbuilder. We are driving a number of strategic initiatives to create and develop meaningful and rewarding careers at Davie today and for generations to come.

2 How does Davie offer a viable career over other industries?

For the first time in decades, Davie is entering a period of prolonged growth and prosperity. The National Shipbuilding Strategy is a unique opportunity to build for a safe and prosperous future for Québec and Canada. An array of key roles and viable career paths are

opening up for existing and the many new employees will recruit. It's also worth noting that shipbuilding as part of the Canadian marine industry overall offer numerous careers paths with competitive salaries and opportunities to grow.

3 What would you say to someone thinking about joining Davie?

Don't hesitate. Contact us today. No other company can offer such an opportunity to make a great impact today, and long into the future.

Quick Q&A



Questions for Ann Gingras (Union leader)
 Présidente du Conseil central de Québec-Chaudière-Appalaches (CSN)

1 Is it gratifying that Davie is set to have assured work for many years as part of the National Shipbuilding Strategy?

Since 2011 when the Government chose two other shipyards for the national strategy, we have been everywhere to make clear that this was an injustice that should be corrected and Davie be recognized for what it is: the best shipyard in Canada. Our strategy, to focus on what Davie is and the potential it has, did not change. That it took so long leaves something of a bittersweet taste.

2 Was it difficult to convince stakeholders to support Davie?

We addressed doubts through the seriousness of the owner: they were here for the long term, they were going to go for all the contracts, that they were prepared to invest. We reached a consensus in Québec to support Davie, to support its workers and recognized the major impact on the local economy. We reached out beyond our union circle to promote Davie. The Mayor of Lévis, Gilles Lehouillier, was a big supporter and wanted Davie to be exploited to its fullest potential as the biggest facility in Canada.

3 What are your thoughts on the Davie workforce?

They are proud of what they do. Proud of what they make and proud of who they are. They are also an extremely

competent and sought-after category of worker. As the national strategy work begins, they also need and deserve more stability and guarantees of work. Davie must also continue to make open communications and respect the basis for the dialogue between the union and its workers.

4 With work set to increase could Davie return to being a generational employer?

When Davie has been really performing there was a father and son thing. There is still a bit of this. In fact, when the national strategy announcement was made, I was sat next to a woman who'd worked at Davie for many years and her first reaction was "I'm going to call my grandson and tell him to apply for a job here".



Asterix Embodies Davie Spirit

The construction and delivery of the Resolve-Class Combat Support Ship m/v Asterix embodied the "Davie Spirit"—our unique sense of collective pride, passion and commitment. The can-do attitude of 1,400 Canadians helped Davie build and deliver Asterix in a record 18 months. At 26,000 tonnes, Asterix was the largest naval vessel ever delivered by a Canadian shipbuilder, with 6,000 tonnes of steel work completed in under a year. Asterix was Canada's first new naval ship in half a century.

What Davie offers



Rewards
 Competitive compensation and benefits



Careers
 Varied, long-term opportunities



Industry Leader
 Québec and Canada



Inclusive Culture
 The Davie Spirit



Security
 NSS work for decades



Purpose
 Keep Canada safe and prosperous



Davie Corporate Overview

Federal Fleet Services crew at work
during sea trials of m/v Asterix

Corporate Social Responsibility

At Davie, how we do business is as important as what business we do.

Responsibilities

The COVID-19 crisis saw Davie sharpen our focus on engaging with and supporting all our stakeholders, including employees, customers and our community and ensuring they are treated fairly and with respect. This approach extends to every part of our business, including indirect employees and thousands of supply chain partners.

Davie's philanthropic responsibilities go beyond charitable donations. Our corporate giving includes longer-term investments and participation in important local projects.



Social

Employee wellbeing, community outreach, customer engagement, corporate giving, education, diversity and inclusion

Generation 2040

Our approach to Corporate Social Responsibility (CSR) goes beyond philanthropy and is fundamental to the long-term sustainability and competitiveness of our business.

Davie's CSR program is called "Generation 2040" and has three interconnected pillars: Social, Economic and Environmental

Economic

Economic including: revenue, profit, competitiveness, impact, job creation, responsible procurement, efficiency, productivity, business practices

Responsibilities

Our own business success is closely connected to Canada's Blue Economy, with its focus on the sustainable use of resources to drive economic growth and improve livelihoods while preserving the marine ecosystem. The Blue Economy promotes the considerable benefits of reuse, recycling and remanufacturing. We have many real-world examples of this, including the three Medium Icebreakers refitted for the Canadian Coast Guard and the combat support ship, m/v Asterix, which began life as commercial container ship.



Environmental

Environmental including: climate change, emissions, pollution, natural resource use, waste control, noise, biodiversity, innovation, product stewardship

Responsibilities

Davie is determined to help preserve our planet for future generations and we want our facilities and operations to be among the world's greenest. We are proud to have been ISO 14001 certified since 2016. Davie has also integrated ISO 14001 with the ISO 9001 Quality standard acknowledging overlapping responsibilities and making our business processes easier to manage and maintain. Asterix, the Canadian Navy's greenest-ever vessel, is also accredited by the Green Marine environmental certification program.

Green Tech

Davie is committed to investing and partnering to deploy and develop the most advanced environmental technologies. Highlights include:

Research & Development

Program: Reduction of ship ecologic footprint project
Partners: Innovation Maritime, NSERC, Université de Laval, UQAR, corporate sponsors

Davie is a proud partner of a research program focusing on the reduction of atmospheric emissions and improvements in energy efficiency from ships operating on the St. Lawrence Seaway.

Propulsion

System: LNG-powered main engines
Partner: Wartsila, Finland
Program: Icebreaking LNG-powered ferries

Davie is Canada's first shipyard to build LNG-powered ships, which create 95% less harmful emissions than conventional propulsion systems.

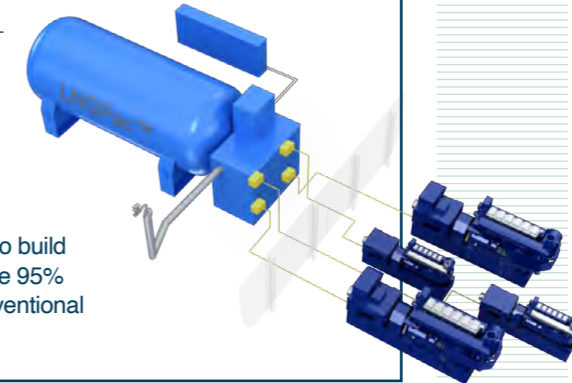

Sustainable Development Goals

Our CSR approach is also informed by and complements the 17 United Nations Sustainable Development Goals (SDGs), which are a blueprint to achieve a better and more sustainable future for all by 2030. Davie has a major indirect responsibility to help mitigate the impacts on our oceans as defined by SDG 14 "Life Below Water", which commits to conserve and sustainably use the oceans, seas and marine resources for sustainable development.



A snapshot of Davie's Sponsorship Programs

Economic Development – SMEs

ExcelCiArt
Chambre de commerce de Lévis

Environment

Regroupement pour la mise en valeur du secteur de la rue St-Laurent

Family and Health

Hôtel Dieu de Lévis
Centre de la famille de Valcartier
Fondation UCPQ
Canadian Cancer Society
Leucan
Centre de pédiatrie sociale de Lévis
CURE foundation

Heritage

Lieu historique national des Forts-de-Lévis

Maritime

Institut maritime du Québec
Musée maritime de Charlevoix
École des technologies supérieures – Engineering Games 2020

Vulnerable Population

Comptoir le Grenier
Invictus Games
Le Tremplin de Lévis
Fondation Jonction Pour Elle
Association de prévention du suicide



Strength in Depth

Teams not individuals win in business. This ethos is personified by Davie's top management, whose diverse and complementary skills are backed up by decades of shipbuilding and general business experience.



James Davies
President and CEO

Before becoming President and CEO in 2019, James Davies was President and CFO for eight years. He is also a founding partner and President of Davie owners, the Inoce Group. Since 2012, James has overseen a transformation of Davie and its financial health while delivering a roster of mission-critical ships. Before Davie, James was CEO of Cambridge Capital Marine, a maritime-focused investment advisor. He was Finance Director of AKN Group responsible for new investments and the management of AKN's existing portfolio. James is a qualified accountant and holds a Bachelor in Accounting and Finance.



Stephen O'Brien
Chief Operating Officer and
Managing Director

Stephen O'Brien has been COO and Managing Director since 2018. He is an industrial engineer who has spent his entire career in shipbuilding. As COO, Stephen's functional responsibilities cover all shipbuilding operations and projects. His management responsibilities include driving a values-driven culture and revitalizing training and continuous improvement programs. He also oversees the implementation of Davie's corporate calendar of commitments. Stephen led the process to secure Davie's first major in-service support contract. Before joining Davie, Stephen held leadership positions with major companies on the East Coast of Canada. His qualifications include a Bachelor of Industrial Engineering and an Executive MBA.



Alban Fournier
Chief Financial Officer

Alban Fournier has been CFO since 2020. He is an international leader with 24 years of experience in all aspects of the finance function, including strategic, corporate, business partnering and controllership. As CFO, Alban heads a function that is increasingly central to the Davie business. Throughout his career, he has led large teams and achieved world-class efficiency and effectiveness. Alban has also successfully driven major business and finance transformations. Before Davie, he spent over 20 years with Rio Tinto, the world's second largest mining company. He held positions of increasing seniority across three continents. Alban holds a Masters in Finance and Economics.



Lindsey Kettel
Executive Vice President

Lindsey Kettel has been with Davie since 2015. Her original mandate was to ensure Davie's business processes supported the delivery of m/v Asterix to the Royal Canadian Navy. Since then, Lindsey's scope of responsibility has increased to include many Strategic Operations, including supply chain activities and Davie's economic impacts program. Before joining Davie, Lindsey consulted for 20+ companies consistently delivering high-value productivity improvement programs in multiple industries. She has been focused on marine construction, conversion and repair industry since 2012. Lindsey has worked with Babcock Canada and Seaspan Shipyards. Lindsey holds a Bachelor of Engineering & Management and an Executive MBA.



Marc Babinski
Secretary and General Counsel

Marc Babinski joined Davie in 2014 following 25 years in corporate commercial practice with a major Canadian law firm. As a member of senior management, Marc takes an active role in the negotiation and conclusion of strategic projects and oversees the legal aspects of yard operations and corporate governance. He is a member of the Davie Board's Risk and Compliance Committee. Marc was admitted to the Law Society of Ontario in 1989 and to the Barreau du Québec in 2009 and holds a Masters in Political Theory from the University of Western Ontario and an L.L.B. from the University of Ottawa.



Richard Allie
Vice President, Operations

Richard Allie has been Vice President, Operations since 2019. In over 11 years with Davie, he has held roles of increasing seniority. Richard's broad field experience is a major asset for Davie, including carpenter/joiner, foreman and leading services and finishing workshops. His considerable production expertise helps to ensure project success and is enhanced from his time with companies such as Polycor and Bocenor Group. In his current role, Richard's responsibilities include yard operations coordination, equipment acquisition, dry docking, security, collective agreement negotiation and budget development for naval operations. Richard served in the Canadian armed forces and has advanced industrial safety qualifications.



Our highly capable and seasoned leadership team is empowering Davie to exceed our customers' needs for generations to come

Alex Vicefield, Founder & CEO Inoce Group



John Schmidt
Sr. Vice President, Commercial and
Government Programs

John Schmidt leads Davie's new business, contract negotiation and business development. John has over 40 years of marine experience in the private and government sectors. He began his career with Westinghouse and subsequently spent 27 years in leadership roles in the Canadian government. He returned to the private sector with Fleetway Inc. and then to Halifax Shipyard as Director of Government Initiatives & Client Relations. In 2013, as VP Commercial, John was instrumental in leading Davie back into federal projects and commercial ship repair. John also Chairs the Canadian Marine Industries and Shipbuilding Association. He holds advanced qualifications in Electrical Engineering Technology.



Naresh Raghubeer
Vice President,
Federal Government Relations

Naresh Raghubeer has spent over 20 years in the development, communication and implementation of public policy. Prior to his current role, Naresh was VP, Communications and Regulatory Affairs for Federal Fleet Services. Naresh previously served as Director of Policy and Parliamentary Affairs in the Senate of Canada. He contributed to the review of legislation on Canadian Security Intelligence Services, Royal Canadian Mounted Police and Communications Security Establishment Canada. Naresh oversaw the development and publishing of more than 25 reports on key topics including: Border Security, UN Deployment and re-equipping of the Canadian Armed Forces. He holds a Bachelor in History and Geography.



Bill Hives
Vice President, Marine Programs

Bill Hives has been with Davie since 2016. He has 30 years of experience in the marine industry. He is responsible for the execution of Davie's major conversion projects, including m/v Asterix and the ongoing refit of three medium icebreakers for the Canadian Coast Guard. After beginning his career at sea, Bill worked with leading oil and gas companies in senior engineering, operations and project management roles around the world. This included Programs Director for the design and construction of technically-advanced Commercial Saturation Diving and Submarine Rescue systems. Bill has advanced qualifications in Project Management, Industrial Measurement, Process Control and Marine Engineering.



Benoit Chassé
Vice President, Human Resources

Benoit Chassé has been VP, Human Resources since 2019. He has more than 25 years of experience as an HR leader across multiple sectors in Canada and internationally. Benoit also has expertise in Occupational Health and Safety, Change Management, Diversity, Corporate Social Responsibility and Communications. In his current role, Benoit leads Davie's HR strategy, including succession planning, training, employer branding and talent management. Benoit also provides strategic and operational labour relations guidance and collective bargaining. He holds a Bachelor in Industrial Relations, is a Six Sigma Deployment Champion and a Member of the Ordre des professionnels en ressources humaines du Québec.



Frederik Boisvert
Vice President, Public Affairs

Frederik Boisvert joined Davie in 2017. He has extensive experience in strategic communications, public relations and business development. In his current role, Frederik has played a key role in building Davie's corporate reputation in Quebec and Canada, as well as creation of the Davie Suppliers Association. Prior to joining Davie, Frederik worked as an issues advisor to the Prime Minister of Canada as well as Chief of Staff for Veterans Affairs Canada and Director of Policy and Communications for various federal ministers, including Transport Canada. He holds a Bachelor in Political Science and Government and a Masters in Organizational Analysis and Development.



Ron Pearson
Vice President, Engineering

Ron Pearson has been VP, Engineering since 2015. He has provided design and engineering leadership on key projects such as the first LNG-powered ferry to be built in North America. Prior to joining Davie, Ron was Shell's Project Site Lead on three Arctic rig upgrade projects in the Pacific Northwest, Korea and Singapore. Before that, Ron was a primary contributor in the development of a new class of diesel-electric platform supply vessels in the Gulf of Mexico. Ron had a 15-year career in naval ship design including the Canadian Patrol Frigate program and a new fast strike craft. Ron is a registered Professional Engineer and holds a Bachelor of Science (Hons) in Mechanical Engineering.



François Gilles Côté
Vice President, Health, Safety, Environment
& Industrial Security

François Gilles has been Vice President HSE & Industrial Security since 2020. He is a seasoned leader with close to 25 years of experience in process engineering, operations management and management of occupational HSE, industrial hygiene and environment. He previously held senior positions in the metallurgical and mining fields with leading companies such as Glencore and Xstrata. François has led a wide range of projects from start-up phase to established plants in Canada and overseas. He holds a Bachelor in Chemical Engineering and has completed extensive executive education programs. He is also a qualified Master in the Positive Attitude Safety System (PASS).



Good Governance

Davie's corporate governance system is based on principles, guidelines and practices that support long-term value creation for our stakeholders.

Our corporate governance commitment is integral to how we run our business. It reflects regulatory requirements, industry best governance practices and the committed leadership of our senior management and Board of Directors.

Our management and Board ensure Davie's corporate governance goes beyond compliance. In fact, it is fundamental to achieving our vision to be Canada's national shipbuilder and an international marine centre of excellence.

It is underpinned by the Davie values, which help define the fair and respectful treatment of our people, suppliers and partners, as well as expectations of how they must conduct themselves on behalf of Davie.

In addition to providing general oversight, our Board supports the definition of Davie's strategic direction. The Board reviews and approves major corporate actions, assesses and manages risk, engages in crisis management and supports succession planning for senior leaders, among other duties.

Davie Board of Directors

James Davies, Chairman, President & CEO, Davie
 Maria Patterson, COO, Inoceca Group
 Russell David, Advisor Inoceca Group
 Paul Gordon, Anchorage Capital

Board Observers

Alex Vicefield, CEO, Inoceca Group | Joseph Saad, JP Morgan

To ensure our Board can effectively execute its duties, we have established the following standing committees. They meet quarterly and consult internal and external subject matter experts on a range of pertinent topics.

Audit

Russell David, Chair
 Maria Patterson
 François R. Roy, external IFRS-GAAP expert

Risk & Compliance

Maria Patterson, Chair
 Marc Babinski
 Pierre Chenard, External Risk Specialist

HR & Compensation

Maria Patterson, Chair
 Russell David
 Marie Letelier, external HR expert

Davie Governance Structure

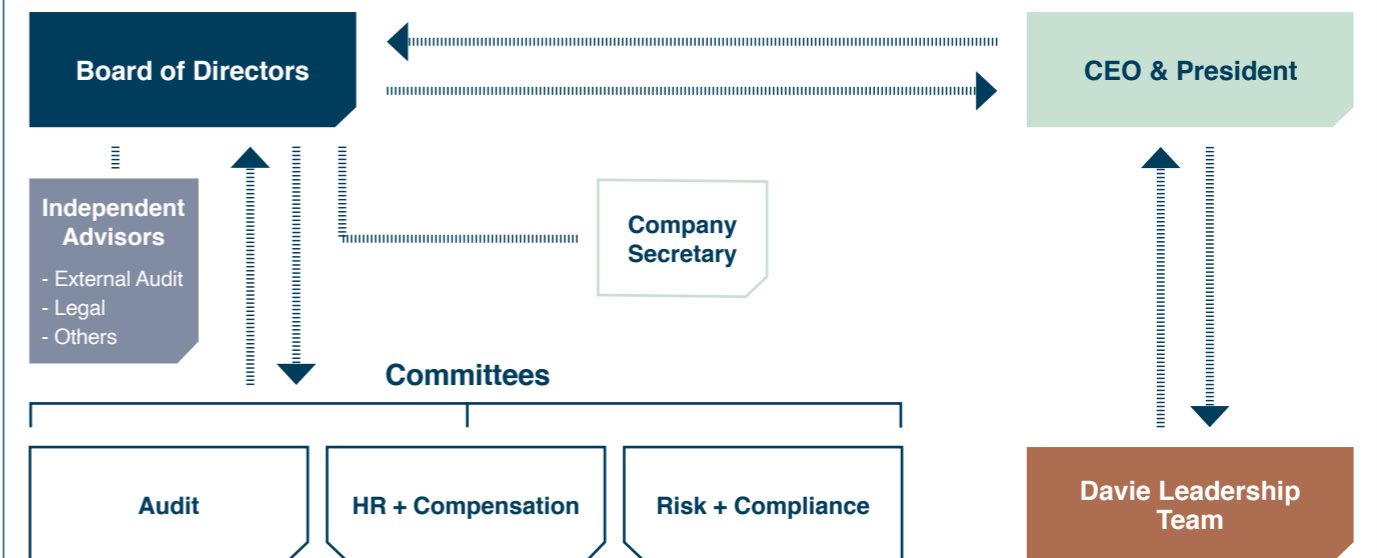

“Davie has adopted a continuous improvement approach to Corporate Governance. We listen to feedback from our stakeholders and incorporate global best practices to enhance our own principles, guidelines and practices.”

Maria Patterson, COO, Inoceca Group

The Davie Board of Directors

The Davie Board of Directors is made up of senior Canadian and international business leaders and renowned subject matter experts. In addition to providing general oversight of the Davie business, Board duties include the review and approval of major corporate actions, risk management and supporting succession planning for senior leaders.



James Davies
Chairman of the Board

Before becoming President and CEO in 2019, James Davies was President and CFO for eight years. He is also a founding partner and President of Davie owners, the Inoceca Group. Since 2012, Mr Davies has overseen a transformation of Davie and its financial health while delivering a roster of mission-critical ships. Before Davie, he was CEO of Cambridge Capital Marine, a maritime-focused investment advisor. Mr Davies was Finance Director of AKN Group responsible for new investments and the management of AKN's existing portfolio. He is a qualified accountant and holds a Bachelor in Accounting and Finance.



Maria Patterson
Director
Chair Risk & Compliance Committee
Chair HR & Compensation Committee

Maria Patterson joined the Inoceca Group as COO in July 2019. Before joining Inoceca, Ms Patterson was an advisor to the Inoceca founders since 2011. She has more than 25 years of experience in international finance, corporate governance and corporate management. In her career, Ms Patterson has managed teams across multiple jurisdictions and worked with leading finance industry professionals worldwide. She is a director on the Boards of Inoceca Group companies and oversees the administration of the group's international entities. Ms Patterson holds a Diploma in Business Studies from University College Dublin, Ireland and is a fully qualified International Trust and Estate Practitioner.



Russell David
Director
Chair Audit Committee

Russell David is a senior advisor to the principals and senior management of the Inoceca Group of Companies. Prior to joining Inoceca in 2016, Mr David held CFO and COO roles in both public and private sector corporations. He was also a senior partner in Canada's largest financial services firm, as President of Deloitte Corporate Finance and served on various company boards of directors. Mr David has been responsible for ensuring companies are well financed and optimally structured to support ongoing operations as well as organic and M&A growth to maximize shareholder returns. Mr David holds CPA, CA and ICD.D (global professional board member certification) designations.



Paul Gordon
Director

Paul Gordon has been a Managing Director of Anchorage Capital Group since 2011. He focuses on providing operational, financial and strategic counsel to companies in which Anchorage has a significant ownership stake. Mr Gordon is also a member of Anchorage's CLO Investment Committee. Prior to joining Anchorage, he was a Managing Director and Portfolio Manager at S.A.C. Capital Advisors and began his investing career at Cerberus Capital Management. Mr Gordon spent the first part of his career in investment banking and leveraged finance. He holds an MBA from the Wharton School and a BA from Cornell University, where he graduated magna cum laude.

Board Observers



Alex Vicefield
Chairman and CEO Inoceca Group

Alex Vicefield is the Chairman and CEO of Inoceca Group, the parent company of Davie Shipbuilding and Federal Fleet Services. Mr Vicefield has spent his entire career in the Marine, Defence and Oil & Gas industries, specializing in project, investment and asset management. Mr Vicefield has been instrumental in a series of major ship, asset and business acquisition, construction and operation projects in Europe, Asia and the Americas.



Joseph Saad
Deputy Head Credit Markets Strategic Situations, JP Morgan

Joseph Saad is Deputy Head of JP Morgan's Credit Markets Strategic Situations. Previously he was Co-Head of Special Situations & Distressed Trading. He worked with investors and issuers of companies that were stressed or distressed, and on other special situations. From 2000-2002, he worked in the Restructuring Group and from 1998-2000 he worked in Global Syndicate Finance. Prior to JPMorgan, Mr Saad worked at First Chicago and at PWC. He has a MBA from Duke University and a B.S. in Accounting from the University of Maryland. He is Captain of the Duke markets recruiting team, a CFA charter holder and a CPA (inactive).

Committee Members



Marc Babinski
Risk & Compliance Committee Member

Marc Babinski joined Davie in 2014 following 25 years in corporate commercial practice with a major Canadian law firm. As a member of senior management, Mr Babinski takes an active role in the negotiation and conclusion of strategic projects and oversees the legal aspects of yard operations and corporate governance. Mr Babinski is a member of the Davie Board's Risk and Compliance Committee. He was admitted to the Law Society of Ontario in 1989 and to the Barreau du Québec in 2009 and holds a Masters degree in Political Theory from the University of Western Ontario and an L.L.B. from the University of Ottawa.



Marie Letellier
HR & Remuneration Committee Member

Marie Letellier is a senior Human Resources executive with over 30 years of experience. She has held key positions in both the public and private sectors across various industries for leading companies such as CAE, Bombardier, Sico Paints and Akzo Nobel. Mrs Letellier has an in-depth knowledge of the Defence sector having spent several years as a civilian employee working for the Department of National Defence in Canada and for the United States Air Force in Washington. Beyond her Human Resources responsibilities, Mrs Letellier has also served as general manager in the maritime transportation sector. She holds a Master's degree from McGill University.



François R. Roy
Audit Committee Member

François R. Roy has been a corporate director since 2010. He was Vice Principal (Administration and Finance) of McGill University from 2007 to 2010. From 2000 to 2003, he was Chief Financial Officer of Telemédia Corporation, a private portfolio company. Prior to this, he was Executive Vice President and Chief Financial Officer of Québecor Inc., an organization focused on telecommunications, entertainment, news media and culture. Mr Roy currently sits on the boards of CBC-Radio Canada, Sollio Group, Enerkem, Noranda Income Fund, Transcontinental and Colabor and was also a Board member of Caisse de dépôt et placement du Québec from 2009 to 2019.



Pierre Chenard
Risk & Compliance Committee Member

Pierre Chenard is an accomplished business executive in the metals and mining industry. In his 30+ year career, he has conducted business in over 40 countries with focus on mergers and acquisitions, major investments, sovereign risk management, joint ventures, corporate finance and strategy. Mr Chenard was EVP, Strategy and Business Development of AngloGold Ashanti, the world's third largest gold miner. He was also SVP, Business Development and General Counsel at Rio Tinto Aluminum. Mr Chenard served as VP and General Counsel at Alcan Inc. He holds Civil Law and Common Law degrees from McGill University and has been a member of the Quebec Bar since 1984.

Davie Board Leadership Skills Matrix





As we fulfil our long-term order book and growing NSS commitments our value creation will accelerate and expand significantly. ”

James Davies, President and CEO



The complex Subsea Construction vessel m/v Pride, built at Davie, in operation

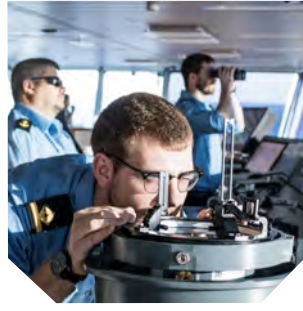

Davie is Canada's premier shipbuilder and a global leader in the delivery of specialist, mission-critical vessels to government and commercial customers. Founded in 1825, Davie is Canada's longest established, largest and highest capacity shipbuilder.

Our world-class workforce build and sustain complex ships that enable our customers to protect national and economic security, or fulfil acute business needs.



Publisher: Inoce Group

Design and Production: Jonathan Saunders Design LTD.

Photography: Mathieu Bélanger

© Inoce Group, 2020